

# Clarity Elite Connect

## PRODUCT DATA SHEET



## Features

- **Wired** – Clarity Elite Connect uses open, industry-standard wired communication protocols and is perfect for installations that require a reliable, physical, wired BACnet and/or Modbus MSTP network for connectivity to your communication enabled edge devices.
- **Powerful** –with a Quad Core CPU processor and 8GB of memory this system has plenty of power to process information, run sequences and store data locally with cloud backup. Control one site or use powerful multi site tools like global schedules and setpoints that allow a user to make one change and roll it out to thousands of locations at once.
- **Future Ready** – combining extra space for additional components inside the enclosure with the power of the Niagara platform and its extensive library of modules and applications, the Clarity Elite Connect has room for future expansion, protecting your investment and eliminating “regret spend”.
- **Distributed Control**– with cloud backup ensures that systems function as intended even when connectivity is lost. Logic, sequences and computing is handled at the edge devices in real time with no lag or hesitation. Data is stored locally and backed up in the cloud ensuring your data is always safe and never lost.
- **Flexible** – use as a stand alone, single controller or link it to other systems using the Niagara network or a Niagara Supervisor for multi-site facilities. Graphical User Interfaces can live locally on the controller, in the cloud on a Niagara Supervisor, and with FSG Smart Buildings web based application, Chariot.
- **Customizable** – develop and apply your own custom logic applications and user interfaces or use FSG Smart Building’s hardened stations and Chariot dashboard.

## Summary

The Clarity Elite Connect with Niagara 4 controller is a fully programmable, UL-listed, control panel assembly with a mix of 34 analog and digital Inputs and Outputs, multiple wired communication protocols across 6 ports, isolated DC power supplies for the controller, and IO overcurrent protection. Housed in a water and dustproof non-metallic enclosure, the Clarity Elite Connect provides power and versatility in a compact, well-constructed assembly designed with installers and service technicians in mind.

## Applications

The Clarity Elite Connect is a flexible, hardened control panel assembly ready to go for applications such as:

### Energy Management

- Open, energy focused Niagara 4 modules ready for ADR, DCV, Optimum Start and Stop, Staggered Start, load shedding and peak demand limiting.
- Customizable local User Interfaces (UI) with different user views including site configuration, commissioning, service tech, and facilities management.

### Building Automation

- Connect to enabled devices with open BACnet, Modbus, TCP, MQTT and API protocols.
- Gather and store data locally and in the cloud, protected against data loss when connectivity fails.
- Take human error out of the equation by automating control of your building equipment.

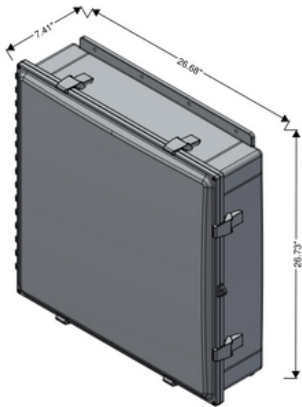

## Specifications

### Inputs, Outputs, and Communication

10 Digital Outputs

8 Analog Outputs

16 Universal Inputs

10/100 Mbps Ethernet (2), RS-485 (4), Type C USB (1)

### Power and Capacity

Powered with a 120V, 20A dedicated circuit

Protected with an integral, 10A fast acting circuit breaker

Dedicated 24VDC power supply for the Niagara Controller and for ancillary devices

Up to 35 Devices and 1,750 Points (expandable)

### Dimensions

Height 26.73"

Width 26.68"

Depth 7.41"

Weight 25.5 pounds

### Details

Enclosure Type - Hinged, latched, pad lockable, NEMA 1, 3R, 4, 4X, 12

Enclosure Material - Polycarbonate

Mounting - Surface mount

Warranty - 1 year

Certifications - UL508-A Industrial Control Panel

