

CompanIO n 34

PRODUCT DATA SHEET



Features

- **Wired**– The CompanIO n 34 uses BACnet MSTP for communication to the Clarity line of panels by FSG Smart Buildings.
- **Versatile I/O**– The CompanIO n 34 panel offers a mix of 34 analog and digital inputs and outputs, providing flexibility to meet a wide range of application needs.
- **Remote**– The CompanIO n 34 panel can be installed up to 4,000 feet (wired distance) away from the primary Clarity panel to provide control of inputs/outputs in remote locations.
- **Scalable**– The CompanIO n 34 allows for easy scalability , enabling you to expand your system as needed without extensive reconfiguration.
- **Durable**– Housed in a water and dust proof non-metallic enclosure, the CompanIO n 34 is designed to withstand harsh enviromental conditions, ensuring reliability and longevity.

Summary

The CompanIO n 34 control panel assembly provides a mix of 34 analog and digital inputs and outputs to expand the capabilities of the Clarity line of panels by FSG Smart Buildings. Housed in a water and dustproof non-metalic enclosure, the CompanIO n 34 provides expanded versatility in a compact well-constructed assembly designed with installers and service technicians in mind.

Applications

The CompanIO n 34 is flexible, hardend expansion panel assembly ready to go to extend your Clarity panel applications

Building Automation

- Lighting Systems
- HVAC Systems
- Security Systems

Energy Management Systems

- Environmental Control Systems

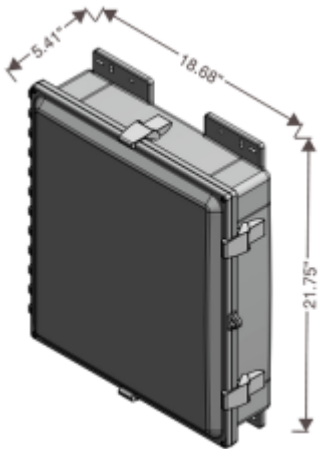

Specifications

Inputs, Outputs, and Communication

10 Digital Outputs

8 Analog Outputs

16 Universal Inputs

BACnet MSTP communication via RS-485 (1)

Power and Capacity

Powered with a 120V, 20A dedicated circuit

Dedicated 24VDC power supply for the Controller and for ancillary devices

Protected with an integral, 10A fast acting circuit breaker

Dimensions

Height 21.75"

Width 18.68"

Depth 5.41"

Weight 18 pounds

Details

Enclosure Type - Hinged, latched, pad lockable, NEMA 1, 3R, 4, 4X, 12

Enclosure Material - Polycarbonate

Mounting - Surface mount

Warranty - 1 year

Certifications - UL508-A Industrial Control Panel